

Plug and Play Crane Kits

Harrington's Plug and Play Crane Kits are high-performance, easy-to-install systems that handle today's most demanding Class "C" applications. Conveniently labeled heavy-duty plugs make installation quick and easy. These kits include standard features that are options on most competitive systems. Applications include fabricating, machining, die handling, assembly, production and maintenance. Rely on Harrington Plug and Play Crane Kits for durability, reliability and years of trouble-free service.



Standard Features

- Capacities: 1 – 10 Ton Top Running; 2 – 5 Ton Underhung
- Heavy-duty, plug-in connections on trolley hoist, end trucks, control panel and crane wiring
- Side guide rollers greatly reduce wheel friction and wear, providing smooth crane travel with increased wheel and runway life
- End trucks come standard with drives, brakes, bumpers, drop stops and rail sweeps
- (N)ER electric chain hoists or RHN wire rope hoists available
- UL/C-UL listed control panel
- CSA and UL listed crane wires and festooning

Crane Service Classifications:

Crane Service Class:

- The Crane Manufacturers Association of America (CMAA) has established six service classes for cranes. These classes are Class A through Class F, and are based on load cycles and load magnitude. Class A cranes are suited for the least severe service, and Class F cranes are suited for the most severe service.

Class C Service Class:

The load cycle and magnitude combinations that define the Class C Service Class are:

- Load is usually between 1/3 and 2/3 of rated capacity and is frequently equal to rated capacity, and design service life is 20,000 to 100,000 cycles.
- Load is usually 1/3 of rated capacity and is rarely equal to rated capacity, and design service life is 100,000 to 500,000 cycles.
- Load is usually very light and rarely is equal to rated capacity, and design service life is 500,000 to 2,000,000 cycles.

Class B Service Class:

The load cycle and magnitude combinations that define the Class B Service Class are:

- Load is usually 1/3 of rated capacity and is rarely equal to rated capacity, and design service life is 20,000 to 100,000 cycles.
- Load is usually very light and rarely is equal to rated capacity, and design service life is 200,000 to 500,000 cycles.

Compliance

In order to meet requirements of the Crane Manufacturers Association of America (CMAA), the National Electric Code (NEC) and the American National Standards Institute (ANSI/ASME), Harrington cranes include:

- Thermal protection for all motors.
- Stationary crane wires that are enclosed in conduit.
- Rubber bumpers for crane and powered trolleys.
- Hoists load tested to 125% of rated capacity.
- Drop stops for cranes.
- Rail sweeps for top running and underhung cranes.

Bridge Crane Control Panels

All motorized bridge cranes require a master panel to control bridge crane functions. Harrington control panels are completely pre-wired and tested, and ready to mount on bridge beam. Standard panel is NEMA 4/12 rated and includes:

Sales order and wiring diagram number for easy reference

VFD
Variable Frequency Drive

Main line contactor allows the crane to be turned on and off from the pendant

Control transformer (with primary and secondary fusing) provides low voltage control circuit for pendant

Through-the-door fused disconnect switch is OSHA compliant lock-out capable

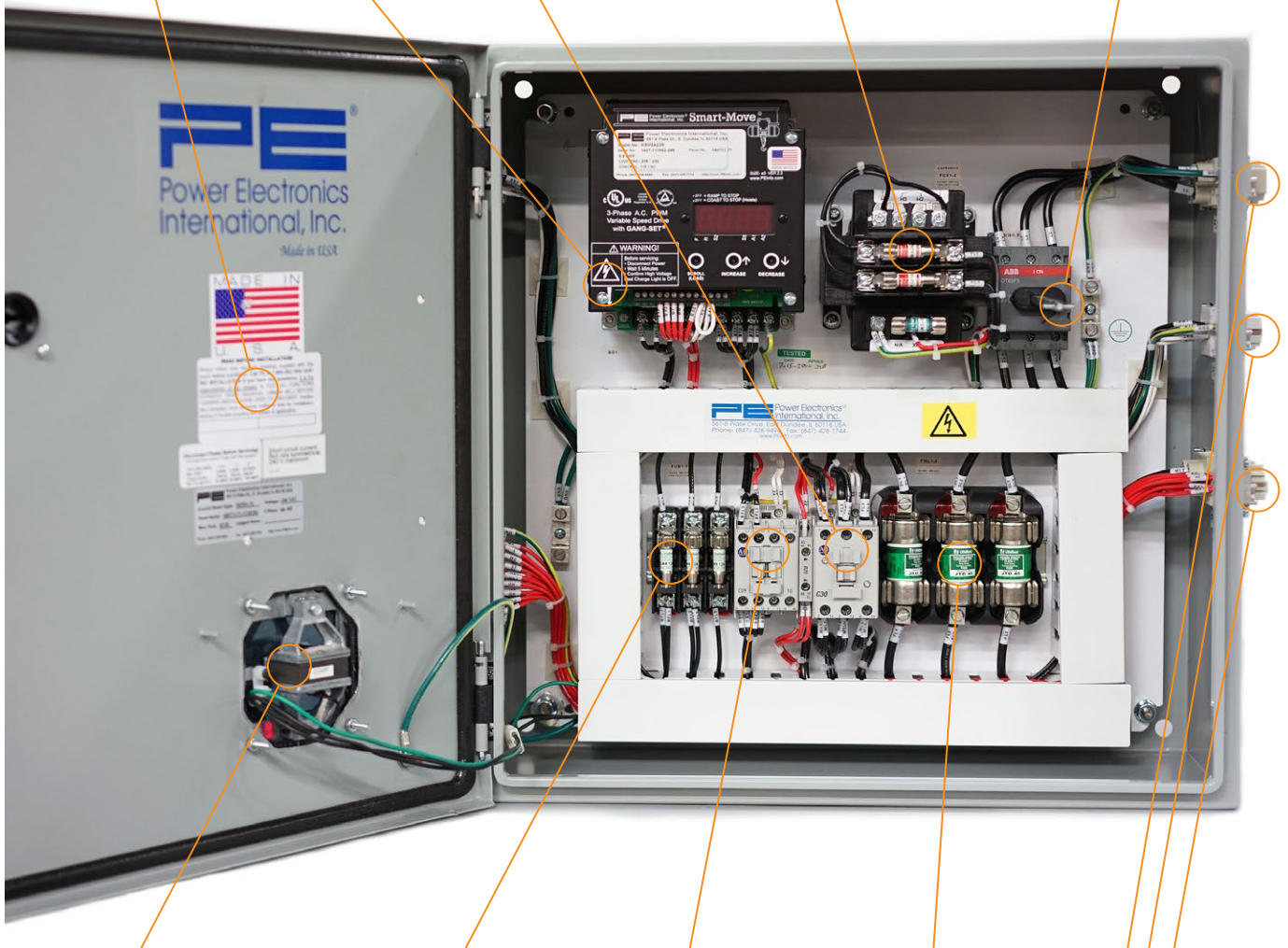

“Warning Device” (horn) as required by CMAA when crane is equipped with a radio powered traversing function

Branch circuit fusing for crane drives

Brake relay

Main line disconnect fusing

Plug and play connectivity

NEMA 4 bridge crane control panels available upon request.

Bridge Crane Control Panels

These panels are for use with all Harrington Series 3 motorized end trucks and are NEC compliant for overhead bridge cranes. All panels include bridge mounting bracket and wiring diagram. Specify voltage when ordering.

Standard Panel – Single and Dual Speeds

All panels are NEMA 4/12 type and cUL US LISTED.

Actual crane drive amps will be determined by system requirements.

Plug and play connection available up to 80A system.

Standard Panel features include:

Lock-out compatible through-the-door manual disconnect switch with system fusing, 110 volt control circuit transformer with primary and secondary fusing, mainline contactor, mechanically interlocked reversing contactor, time and torque adjustable Electronic Acceleration Control (EAC), branch circuit fusing for bridge, auto-reset thermal overload relay and hinged door.

Optional Panel – Variable Frequency Drive (VFD)

All panels NEMA 4/12 type and cUL US LISTED.

Actual crane drive amps will be determined by system requirements.

Plug and play connection available up to 80A system

Optional Panel features include:

Lock-out compatible through-the-door manual disconnect switch with system fusing, 110 volt control circuit transformer with primary and secondary fusing, mainline contactor, Variable Frequency Drive (VFD), brake relay, branch circuit fusing for bridge and hinged door.

These panels can be used for dual- and multiple-speed applications, infinitely variable speed applications and programmed acceleration/deceleration control, using single-speed end trucks. VFD comes pre-loaded with many easy-to-select programs to fit virtually any crane control application and includes fault-code troubleshooting

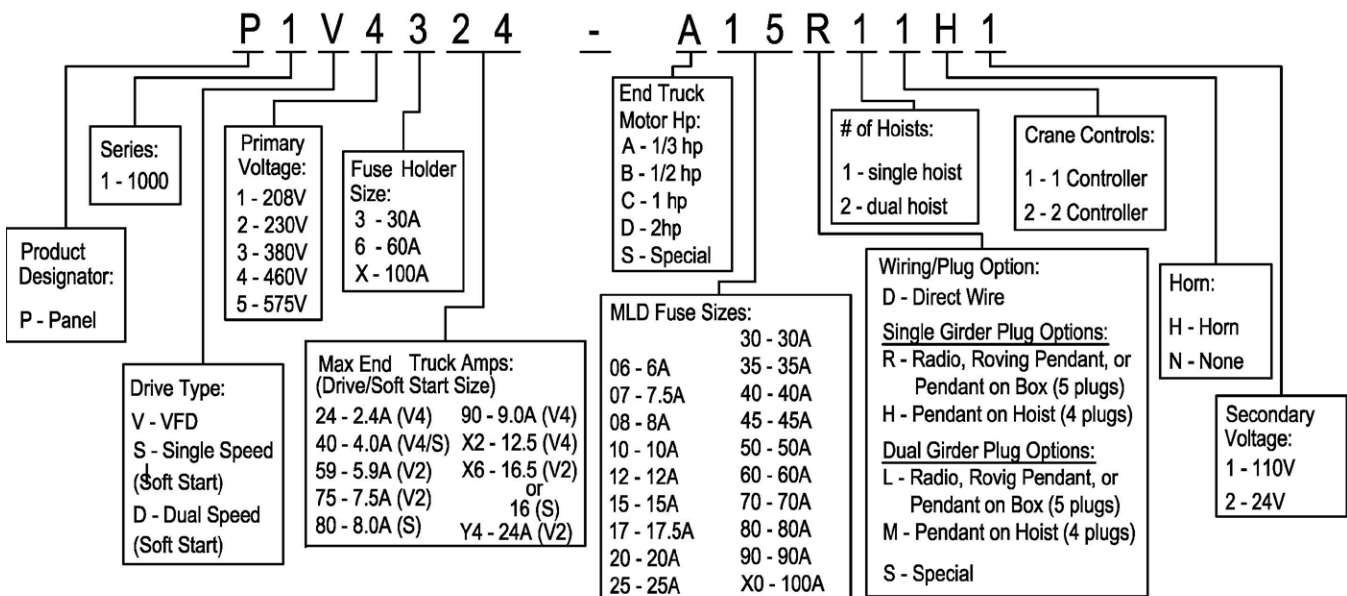

Product Code

Motor and Brake

Harrington motorized cranes are dual drive type, employing two totally enclosed non-ventilated drives per crane. Drives use helical and spur gearing and are equipped with adjustable DC brakes.

Rugged helical and spur gears
provide reliable and quiet operation

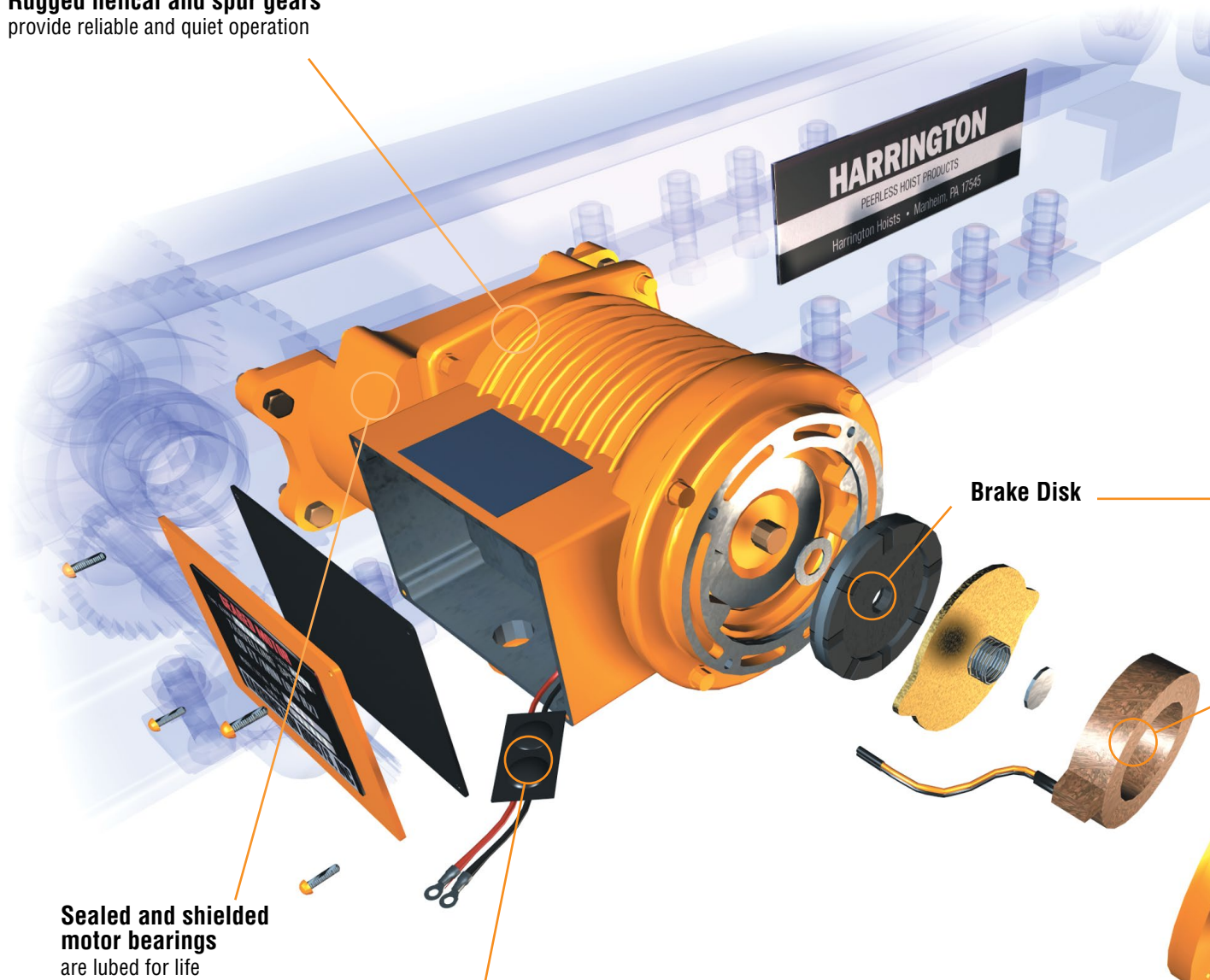

Brake Disk

Sealed and shielded motor bearings
are lubed for life

Rectifier
for brake circuit supplies DC voltage to brake coil

Series 3 Underhung Crane Drive Wheels

Harrington's motorized and geared underhung cranes use a gear system that drives two of the four wheels on each end truck. All Series 3 underhung cranes have two bearings in each wheel.

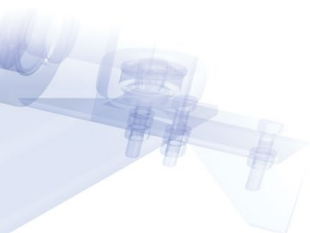

Brake assembly is easy to adjust and is controlled by an independent DC circuit for compatibility with standard, EAC, or Variable Frequency drive control

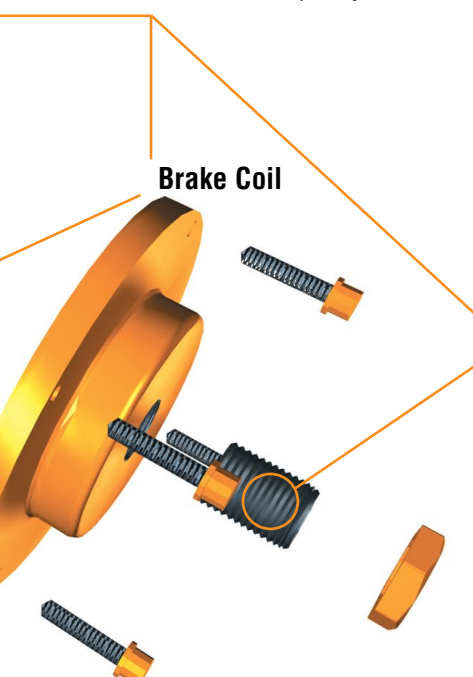

Brake Coil

Adjusting Bolt

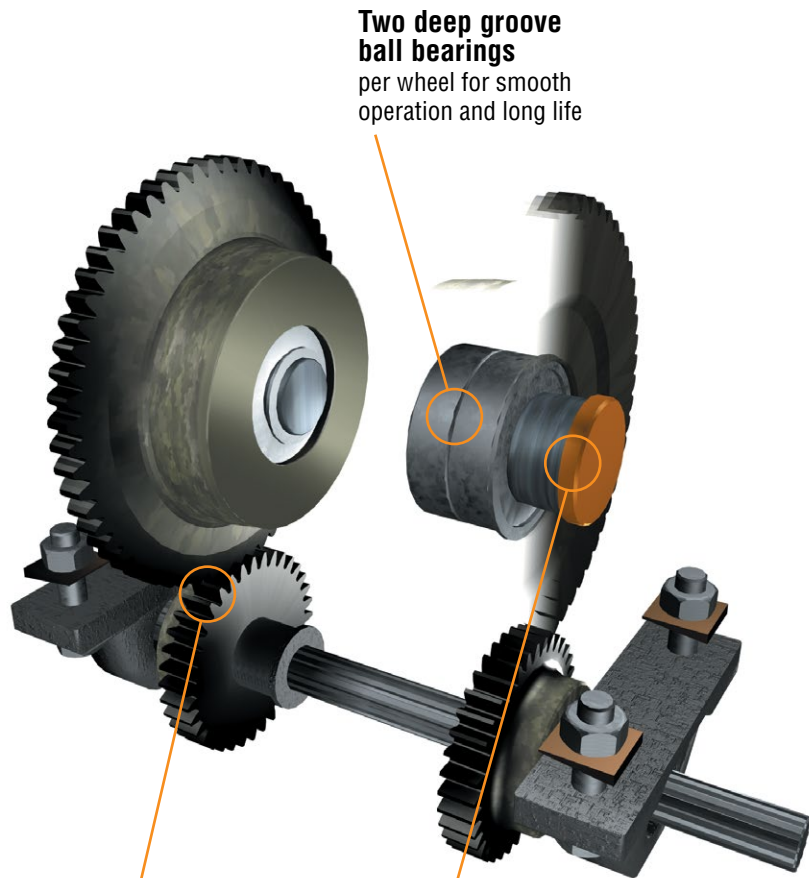

Two deep groove ball bearings per wheel for smooth operation and long life

Induction-hardened steel gears provide synchronous power to paired drive wheels

Stationary axles welded to end truck frame for ruggedness

Bridge Beam Selection Charts

SERIES 3 — SINGLE GIRDER BEAM SIZES

Bridge beam sizing is based on Harrington chain hoist products' weights and speeds and are for indoor use only. For outdoor applications, consult customer service.

Maximum Allowable Span (ft)	Capacity (Tons)						
	1/2	1	2	3	5	8	10
10	S8x18.4	S8x18.4	S10x25.4	S12x31.8	S12x40.8	W18x71	W21x93
15	S8x18.4	S8x18.4	S10x25.4	S12x40.8	S15x50	W21x83	W18x106
20	S8x18.4	S10x25.4	S12x31.8	S15x42.9	S15x42.9 C8x11.5	W21x93	W18x119
25	S10x25.4	S10x25.4	S12x31.8 C8x11.5	S15x42.9 C8x11.5	S15x42.9 C10x15.3	W24x103	W24x103 C12x20.7
30	S10x25.4	S12x31.8	S15x42.9	S15x42.9 C10x15.3	W16x77	W24x103	W27x129
35	S12x31.8	S15x42.9	S15x42.9 C8x11.5	W16x67	W21x83	W27x114	W30x148
40	S15x42.9	S15x42.9 C8x11.5	W18x60	W18x71	W21x83	W27x114 C12x20.7	W27x129 C15x33.9
45	S15x42.9 C8x11.5	W16x57	W18x71	W18x76	W24x94	W27x114 C15x33.9	W30x148 C15x33.9
50	W16x40	W18x60	W18x76	W21x83	W27x102	W30x124 C15x33.9	W30x148 C15x33.9
55	W16x57	W16x67	W21x83	W24x94	W27x114	W30x132 C15x33.9	W30x148 C15x33.9
60	W16x67	W18x76	W21x93	W27x114	W30x116 C15x33.9	W33x141 C15x33.9	W33x169 C15x33.9

Note: Above channel caps are span less 10'0" for overall length. Consult Customer Service for wire rope hoist beam sizes.

HPC RECOMMENDED BRIDGE BEAMS — ELECTRIC HOIST

Bridge beam sizing is based on Harrington chain hoist products' weights and speeds and are for indoor use only. For outdoor applications, consult customer service.

1. Includes 15% allowance for Electric Hoist load factor.
2. Based on Harrington's electric chain hoist product.
3. For spans greater than 10 ft, braces between end truck and bridge beam are recommended.

Capacity (Tons)	Maximum Allowable Span (ft)			
	10	15	20	24
1/2	S8x18.4	S8x18.4	S8x18.4	S10x25.4
1	S8x18.4	S8x18.4	S10x25.4	S10x25.4
2	S10x25.4	S10x25.4	S12x31.8	S12x31.8 C8x11.5

Product Specification Form

Harrington Complete Crane Systems

HARRINGTON COMPLETE CRANE SYSTEMS

Quantity _____
 Capacity _____ (Ton)
 Span _____
 Voltage _____ (If Motorized)
 Runway Length _____

Crane Type _____ Single Girder _____ Double Girder
 _____ Top Running _____ Underhung

Structure _____ Rail Size (If Top Running) _____ Runway Beam Size (If Underhung)

Bridge Travel _____ Motorized _____ Push _____ Geared
 (If Motorized) _____ Single Speed _____ Dual Speed _____ VFD _____ Desired Speed
 (If Geared) _____ Hand Chain Drop (feet)

Specials: _____

Bridge Beam _____ Required _____ Existing _____ Beam Spec. (If Existing)

Hoist Type _____ Manual Chain _____ Electric Chain _____ Electric Wire Rope
 Lift _____ Feet
 (If Electric) _____ Single Speed _____ Dual Speed _____ VFD _____ Desired Speed

Options: _____ Canvas Chain Container

Specials: _____

Trolley Type _____ Motorized _____ Push _____ Geared
 (If Motorized) _____ Single Speed _____ Dual Speed _____ VFD _____ Desired Speed
 (If Geared) _____ Hand Chain Drop (feet)

Specials: _____

Form completed by:

Name _____ Company _____

Phone _____ Fax _____

Address _____ City _____ State _____ Zip _____

E-Mail Address _____ Copy & fax to 717-665-7432

Options

Plug and Play Connections

- End Trucks
- Crane Control Panel L
- Crane Wires
- Trolley/Hoist

Flat Cable Festooning

- Roving pendant
- Hoist/trolley power
- Runway—crane power

Variable Frequency Control

- Multiple speeds
- Infinitely variable speeds
- Programmable acceleration and deceleration

Remote Control

- Radio
- Infrared
- Wall-mounted pendant (hard-wired)

24V Control Voltage

(110V is standard)

NEMA 4, 4X, 12, or 13 Bridge Control Box

(NEMA 4/12 is standard)

NEMA 4 or 4X Pendant

Warning Devices

- Lights
- Audible alarms

Enclosed Conductor Electrification

- Bridge
- Runway

Multiple Hoists on Single Bridge

Power Supply—Other Voltages Available

Interlocking Bridges

Patented Track Runway Applications

(3 1/4" and above)

Travel Limit Switches

Load Limiting Device

Special Applications

Glossary of Common Crane Terms:

Adjustable brakes: Electro-mechanical device to control horizontal crane deceleration.

Bridge beam: Traveling beam connected to end trucks - supports trolley hoist and load.

Bumpers: Energy absorbing device mounted on end trucks or trolley that reduces impact when the truck or trolley contacts either its end stop or another truck or trolley.

Capacity: Maximum rated load which a crane is designed to carry. Commonly expressed in Tons. (1 Ton = 2,000 lbs.).

Drop stops: Means to limit the drop of a bridge or trolley in case of wheel or axle failure.

Electronic Acceleration Control (EAC): Electronic control for adjusting rate of crane acceleration; also known as Electronic Soft Start.

End truck: Load-bearing crane component that supports the bridge beam and consists of a frame, wheels, axles, etc.

Festooning: Wiring and support system that delivers power to trolley hoist across bridge or runway beam.

Rail sweeps: Device designed to clear obstructions from wheel running surface.

Runway beam: Stationary beams that support crane and load. Commonly fabricated from S or W beams or patented track.

Runway electrification: Delivers power to crane as it travels along runway.

Span: Dimension from one runway centerline to the other runway centerline.

System max wheel load: Maximum load exerted on runway beams for a crane loaded to its rated capacity. It occurs when trolley hoist is located at its maximum end approach and includes an allowance for vertical inertial forces associated with electric hoists. This value is expressed for Series 3 cranes as lbs/wheel for top running and lbs/wheel pair for underhung cranes. For Series HPC 500 cranes, both top running and underhung are lbs/wheel pair.

Top running: Crane type that travels on top of rail or bar attached to runway beams.

Underhung: Crane type that travels on the lower flange of runway beams.